

Figure 1. Dimensions

Description and Operation

Edwards Adaptatone is a heavy-duty, tone-selectable, stand alone, indoor/outdoor audible signaling device intended for industrial applications where high audible output and microcomputer reliability are required. Catalog Numbers ending with suffixes -24AQ or -24Y6 are CE Marked and TÜV-RHEINLAND Certified for compliance to the European Union's Electromagnetic Compatibility (Industrial) and Low Voltage Safety Directives (see Declaration of Conformity, available upon request). Additionally, the Adaptatone Millennium series are UL and cUL Listed as Audible Signal Appliances for use in the following hazardous locations.

Catalog Number	Hazardous Locations	Temp. Code
5530M-24AQ 5530M-24N5 5530M-24Y6 5530M-120N5* 5530M-120Y6* 5530MHV-24AQ 5530MHV-24Y6 5530MHV-120Y6*	Class I, Div. 2, Groups A, B, C, D Class II, Div. 2, Groups F, G Class III, Div. 1 and 2	T4 (135C) T5 (100C)

*Catalog Numbers ending in -120Y6 or -120N5 are NOT cUL Listed.

The Adaptatone operates from local power and sounds a high decibel signal determined by the setting of miniature programming switches inside the unit. The Adaptatone may be programmed for any of the 27 tones listed in Figure 16.

Speaker direction and the output level are easily adjustable.

Mechanical Specifications

Weight 9 Pounds (4.1 kg)

Hazardous Locations, UL Standard UL1604

Ambient Temp. +41F to +104F (+5C to +40C)

Non-Hazardous Locations

Variable Ambient Temp. -40F to +151F (-40C to +66C)

Hazardous Locations and Variable Ambient Conditions apply only where UL listings are accepted and do not apply to CE conformity or TÜV-Rheinland Certification.

Electrical Specifications

Catalog Number	Input Board		Main Power		
	Voltage	Current	Voltage	Current (A)	
Standard Volume					
				Standby	Tone On
5530M-24AQ	24V DC	6 mA	24V DC 24V AC 50/60 Hz	0.10	0.74 1.3
5530M-24N5	24V DC	6 mA	120V AC 50/60 Hz	0.10	0.36
5530M-120N5	120V 50/60 Hz	13 mA	120V AC 50/60 Hz	0.10	0.38
5530M-24Y6	24V DC	6 mA	125V DC* 250V DC* 120V AC 50/60 Hz 240V AC 50/60 Hz	0.10 0.02 0.10 0.10	0.21 0.10 0.32 0.20
5530M-120Y6	120V 50/60 Hz	13 mA	125V DC* 250V DC* 120V AC 50/60 Hz 240V AC 50/60 Hz	0.10 0.02 0.10 0.10	0.20 0.10 0.31 0.20
High Volume					
5530MHV-24AQ	24V DC	6 mA	24V DC 24V AC 50/60 Hz	0.10 0.10	1.5 2.3
5530MHV-24Y6	24V DC	6 mA	125V DC* 250V DC* 120V AC 50/60 Hz 240V AC 50/60 Hz	0.10 0.02 0.10 0.10	0.39 0.19 0.56 0.34
5530MHV-120Y6	120V 50/60 Hz	13 mA	125V DC* 250V DC* 120V AC 50/60 Hz 240V AC 50/60 Hz	0.10 0.02 0.10 0.10	0.40 0.20 0.62 0.37

*CE mark and TÜV-Rheinland Certifications do not apply to 125V DC or 250V DC.

Installation

The Adaptatone may be mounted to any flat surface or may be used as a freestanding unit mounted to a rigid pipe. The Adaptatone must be installed in accordance with the latest edition of the National Electrical Code or other regulations applicable to the country and locality of installation and by a trained and qualified electrician.

For catalog numbers ending in "AQ", 24V AC power must be transformer isolated from mains or line power.



CAUTION

During installation, care must be taken so that components on the printed circuit board are not damaged.

1. Mount Adaptatone as shown in Figure 2.

- Flat Surface Mounting.** Secure unit to mounting surface using the (4) mounting holes in the mounting plate on the rear of the box. Use the #10 x 3" (76 mm) wood screws (furnished loose) or other hardware (not supplied) suitable for the mounting surface.
- Rigid Pipe Mounting.** Loosen the (4) cover screws from the signal box and lift off signal box cover.

Table 1. Programming Logic Controller (PLC) Compatibility: PLC output to meet following product input parameters. See Figures 11 and 14.

Cat. No.	Operating voltage (Volts)	Max. off state leakage current (mA)	Continuous on current (mA)	Surge (inrush/duration) (Amps/milliSeconds)
5530M-24AQ	24V DC only	2	740	8/4
5530M-24N5	120V 60 Hz	2	360	2.82/4
5530M-120N5	120V 60 Hz	5	380	2.82/4
5530MHV-24AQ	24V DC only	2	1500	8/4
Input Board Circuit	24V DC	2	6	--
Input Board Circuit	120V 60 Hz	5	13	--

NOTE: Cover screws are captive. Do not remove from cover.

Remove the center knockout in lower wall of box and mount box to a 1/2" (12.7 mm) conduit pipe using suitable connector.

2. Install wires through a knockout hole in the bottom of the box from a raceway that is, with its connections to the 1/2" (12.7 mm) conduit knockout hole, approved for the same degree of protection and enclosure type needed by the application. Use the provided plastic tie-wrap, on the barrier to the electronics, to separate incoming power leads from signal and tone initiating leads, per NEC (Figure 5).

WARNING

To prevent fire and shock, wire the Adaptatone only as described in this installation instruction.

3. Wire as follows referring to Figure 5.
 - a. Connect green and yellow-striped earth-ground wires to earth-ground.
 - b. Select the appropriate method for wiring to the input board from Figures 6 - 11 for models with 24V input board or Figures 12 - 14 for models with 120V input board.
 - c. Connect incoming power to wire leads using a butt splice or other method listed, certified, or otherwise approved by local authorities. Leads are both black for -AQ and -N5 models and are black and white for -Y6 models.

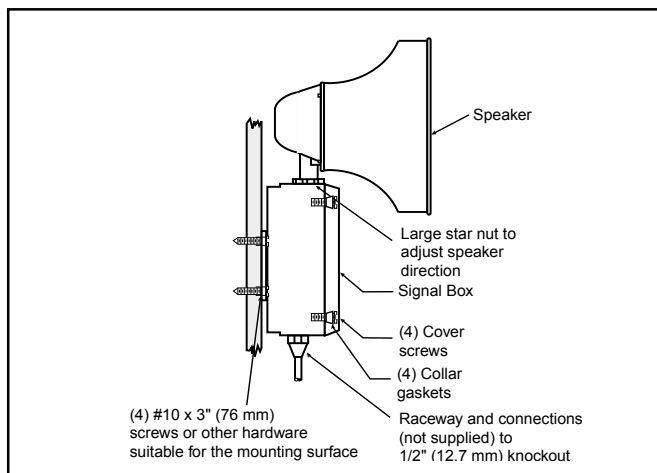

Figure 2. Adaptatone Mounting

- d. Optional. Connect external 24V DC battery (not supplied) in series with separate diode assembly part 2600010 (supplied) to TB1 terminals 3 and 4 on the main board as shown in Figures 3 and 4 and marked on the diode assembly.

NOTE: Terminal Block TB1 can be unplugged from the main board to complete wiring as shown in Figure 3.

4. Refer to Figures 15 and 16 and select desired tones. Set miniature programming switches on the input board.

WARNINGS

HIGH VOLTAGE is present when product is energized. High volume may cause harm to personnel in close proximity.

5. Adjust volume level, if desired, by turning potentiometer located on the main board (Figure 11).

WARNING

To ensure integrity of the Adaptatone assembly when adjusting the speaker direction, make sure threads in the enclosure remain fully engaged and do not turn speaker more than 360 degrees from the original factory installed position.

6. To adjust speaker direction, loosen large star nut (Figure 2) and turn speaker to the approximate desired position. Retighten nut and turn speaker slightly clockwise until locked into place.

WARNING

To ensure integrity of the enclosure: Ensure the cover gasket, part number P-007549-0069, is adhered into groove at cover perimeter before replacing the signal box cover.

Ensure that the (4) collar gaskets, part number P-041930-0362, are in place on each cover screw before securing the signal box cover.

When securing cover, start screws by hand, making sure they are threaded into tapped holes in housing bosses before securing with a screwdriver. Torque signal box cover screws to a minimum of 20 in-lbs. This ensures the required tight fit.

7. Tightly secure the signal box cover using (4) retained cover screws.
8. Torque signal box cover screws to a minimum of 20 in-lbs.

9. Verify operability.

Maintenance and Test



CAUTION

Ensure that power is disconnected before cleaning inside of unit.

Examine the unit semi-annually for accumulation of dirt. Clean if necessary.

The Adaptatone should be tested annually or as required by the authority having jurisdiction to ensure continuous service.

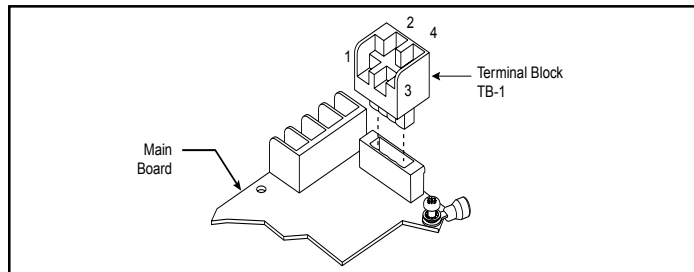

Figure 3. Terminal Block TB1

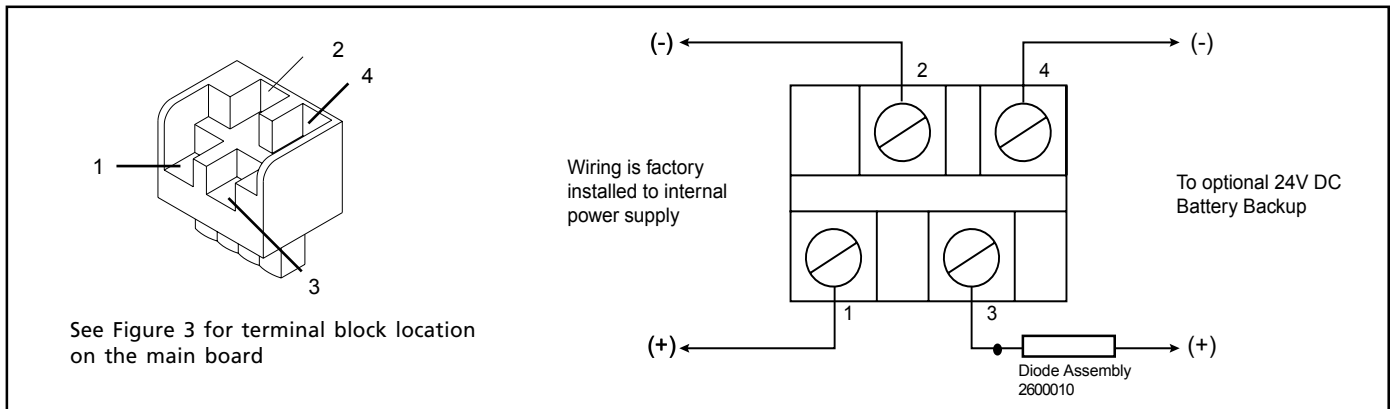

Figure 4. Wiring to Terminal Block TB1 Input Circuit

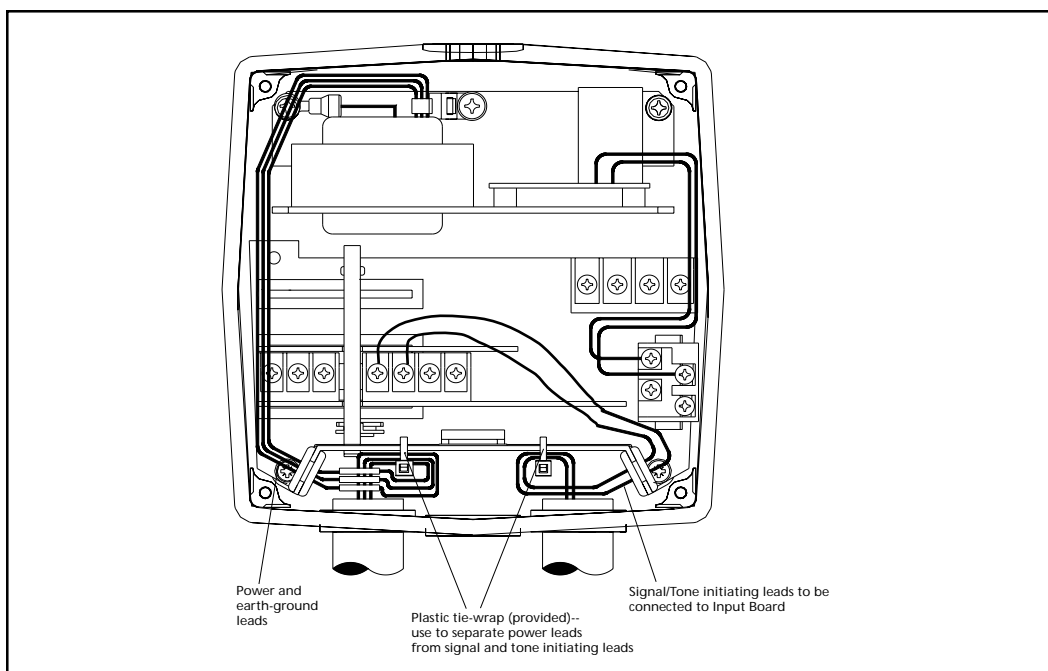

Figure 5. Wiring the Adaptatone

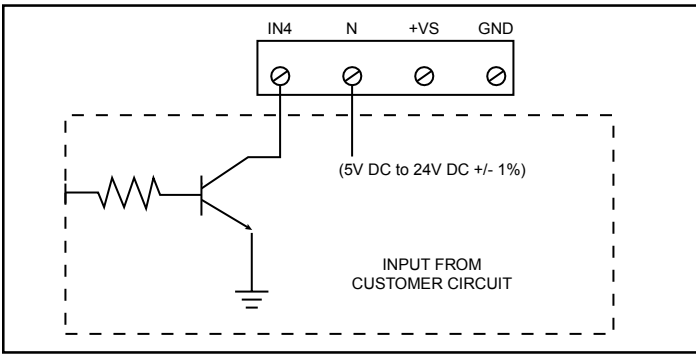

Figure 6. Wiring to 24V Input Board with an Open Collector Transistor

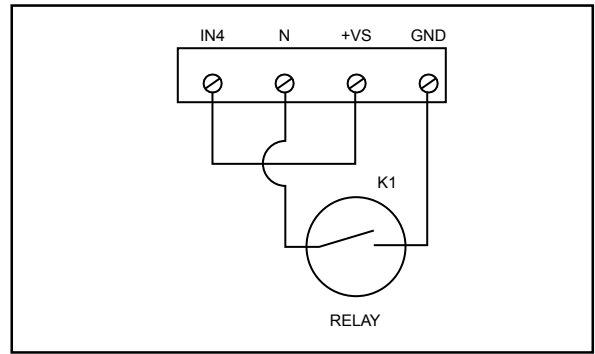

Figure 7. Wiring a Dry Relay Contact to 24V Input Board, Method 1 (Refer to Applications Engineering for compatibility with earlier versions of Adaptatone)

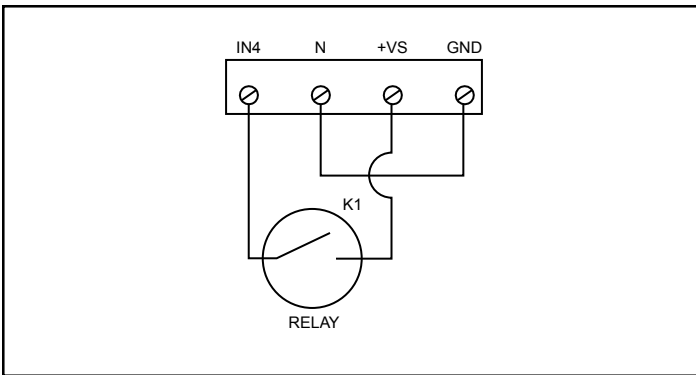

Figure 8. Wiring a Dry Relay Contact to 24V Input Board, Method 2

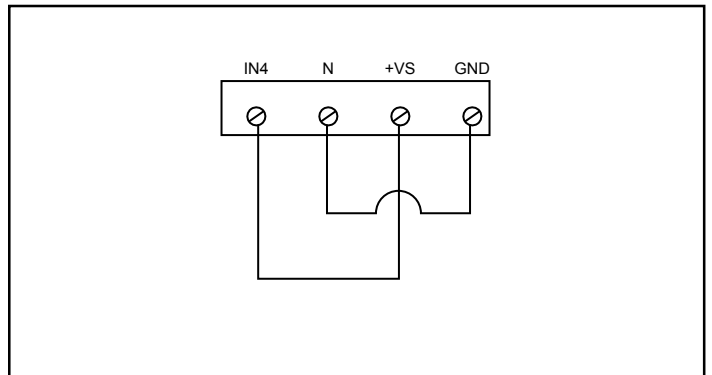

Figure 9. 24V DC Strapped Input, 24V Input Board

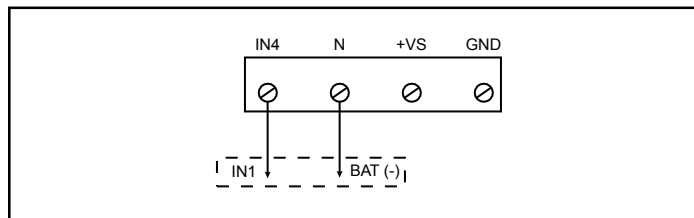

Figure 10. Connecting 24V Input Board in Parallel with Adaptatone "B" (limit of 5 "M" models)

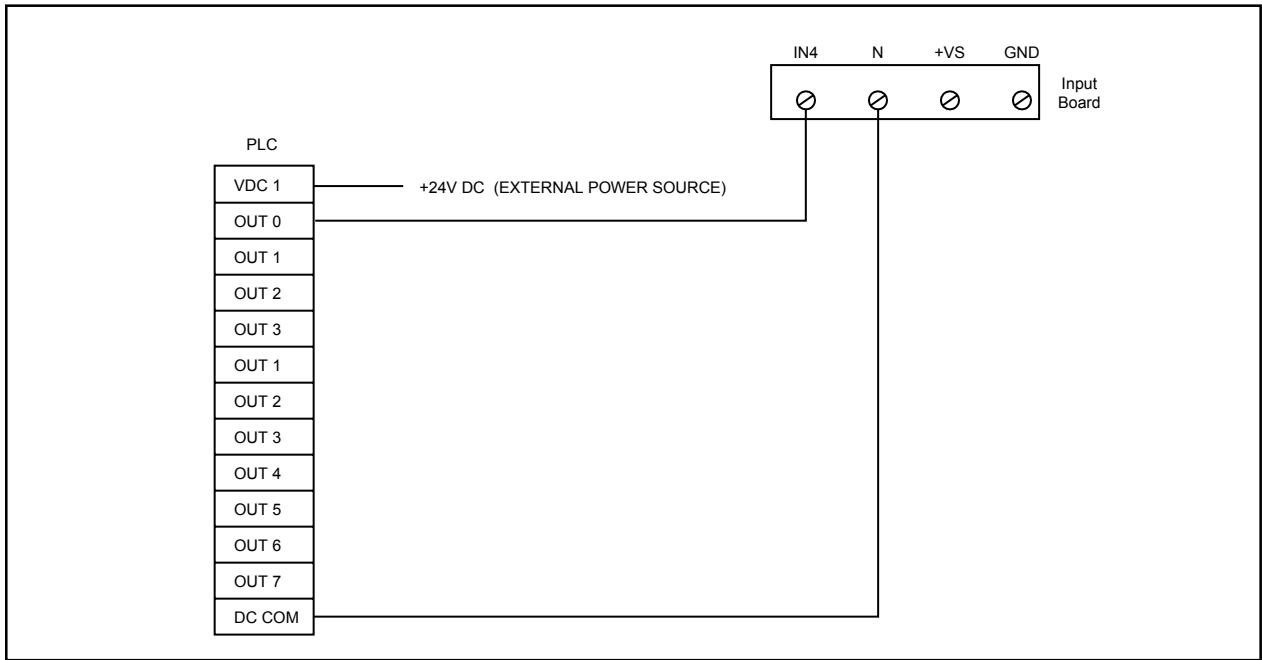

Figure 11. Connecting 24V Input Board to a PLC. See Table 1.

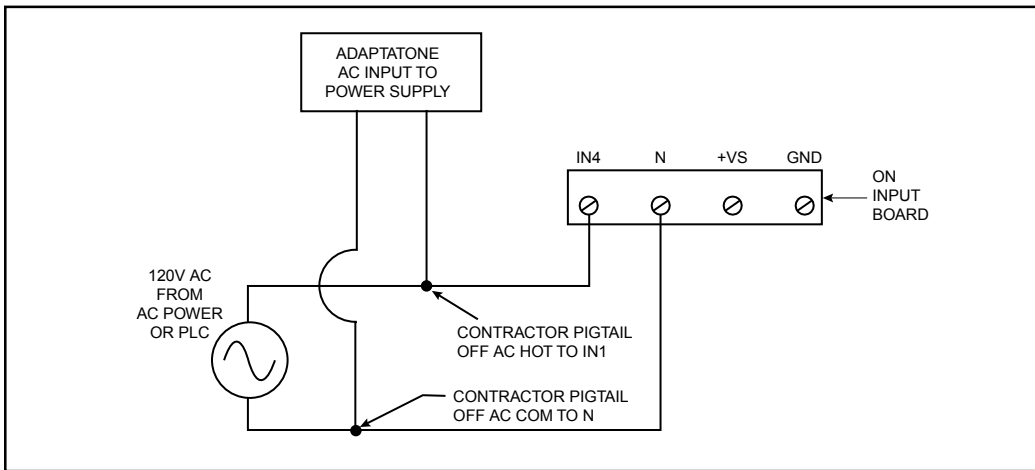

Figure 12. 120V AC Strapped Input, 120V Input Board

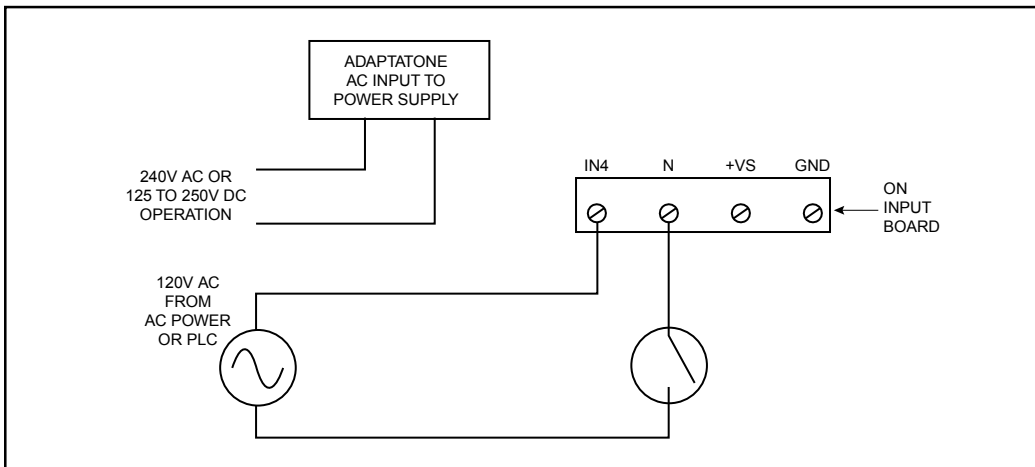

Figure 13. 120V AC to 240V AC or 120V DC - 250V DC, 120V Input Board

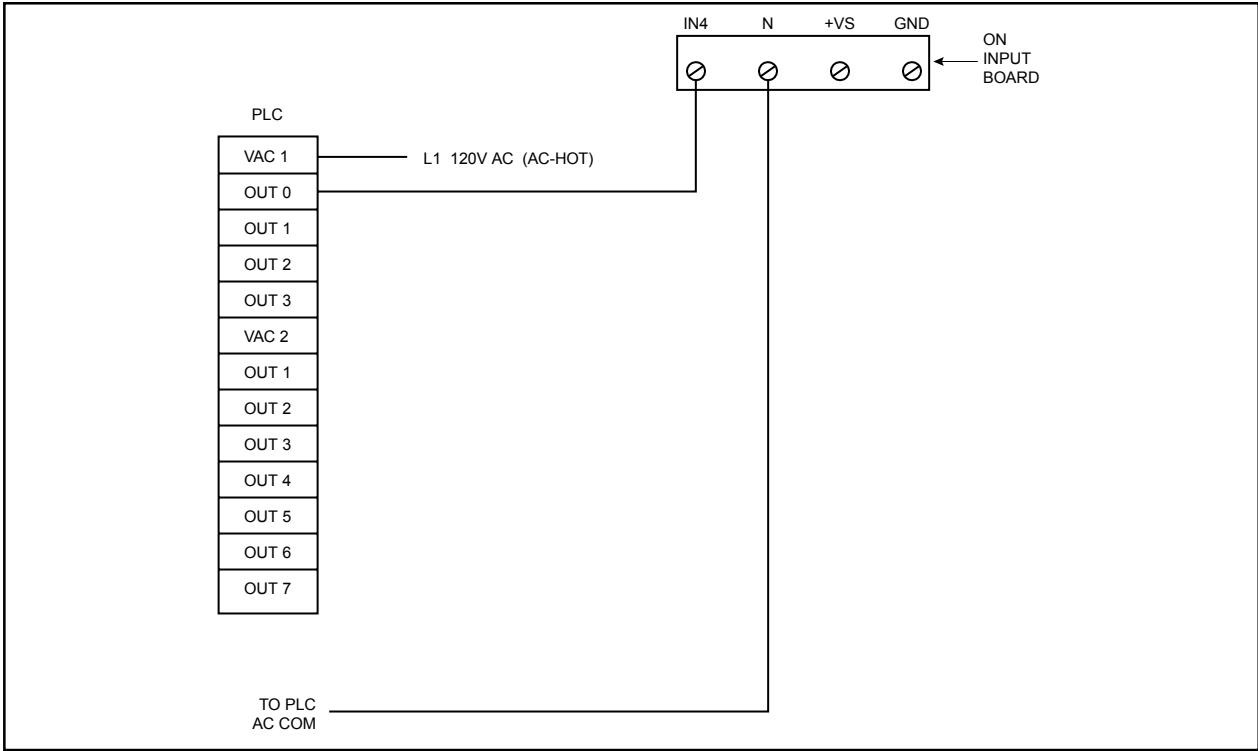

Figure 14. Connecting From a PLC to 120V Input Board. See Table 1.

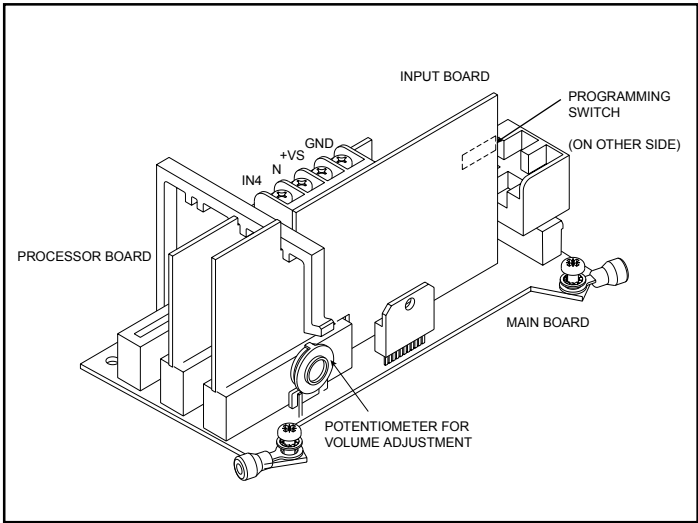

Figure 15. PC Board Locations

Figure 16. Tone Programming

Tone	Description	Switch					HEX
		1	2	3	4	5	
No Tone		○	○	○	○	○	00
Ding-Dong	Percussive pairs of 700 and 570 Hz tones, each damped to zero	●	○	○	○	○	01
Warble	575 and 770 Hz alternately, 87 ms each	○	●	○	○	○	02
Siren	600-1250 Hz up and down sweep in 8 seconds and repeat	●	●	○	○	○	03
Stutter	Percussive 470 Hz, 83 ms on, 109 ms off	○	○	●	○	○	04
Slow Whoop	600-1250 Hz upward sweep in 4 seconds and repeat	●	○	●	○	○	05
Beep	470 Hz, 0.55 seconds on, 0.55 seconds off	○	●	●	○	○	06
Chime 1	700 Hz percussive repeat at 1 Hz	●	●	●	○	○	07
Fast Whoop	600-1250 Hz upward sweep in 1 second and repeat	○	○	○	●	○	08
Hi/Lo	780 to 600 Hz alternately, 0.52 seconds each	●	○	○	●	○	09
Rapid Siren	600-1250 Hz up and down sweep in 0.25 seconds and repeat	○	●	○	●	○	0A
Yeow	1250-600 Hz downward sweep in 1.6 seconds and repeat	●	●	○	●	○	0B
Horn	470 Hz continuous	○	○	●	●	○	0C
Air Horn	370 Hz continuous	●	○	●	●	○	0D
Dual Tone	450-500 Hz, 0.4 to 0.5 second cycle	○	●	●	●	○	0E
Chime 2	575 Hz percussive repeat at 1 Hz	●	●	●	●	○	0F
Westminster	Two measures, 411 Hz, 520 Hz, 407 Hz, 312 Hz	○	○	○	○	●	10
Three Blind Mice	Four Measures, 787 Hz, 714 Hz, 625 Hz, 952 Hz, 333 Hz	●	○	○	○	●	11
Phasor	416-625 Hz up and down sweep in 13 ms and repeat	○	●	○	○	●	12
Telephone	570 and 770 Hz alternately, 50 ms each for 1.2s, 1.5s delay and repeat	●	●	○	○	●	13
Staircase	440-2000 Hz up and down steps, 750 ms delay and repeat	○	○	●	○	●	14
3 Tone Alert	463, 641 and 896 Hz, 200 ms each, 1 second delay and repeat	●	○	●	○	●	15
Presignal Chime	470 Hz percussive repeat at 1.5 Hz, followed by Message 1	○	●	●	○	●	16
NFPA Whoop	422-775 Hz, upward sweeps, 850 ms each, 1 second delay and repeat	●	●	○	●	●	1B
3 Pulse Horn	470 Hz, 3 0.5 second pulses separated by 0.5 seconds followed by a 1.5 second delay and repeat-- For Evacuation Use Only	○	○	●	●	●	1C
3 Pulse Air Horn	370 Hz, 3 0.5 second pulses separated by 0.5 seconds followed by a 1.5 second delay and repeat-- For Evacuation Use Only	●	○	●	●	●	1D
3 Pulse Dual Tone	450-500 Hz, 0.4 to 0.5 second cycle, 3 0.5 second pulses separated by 0.5 seconds followed by a 1.5 second delay and repeat-- For Evacuation Use Only	○	●	●	●	●	1E
3 Pulse Chime 2	575 Hz, 3 0.5 second pulses separated by 0.5 seconds followed by a 1.5 second delay and repeat-- For Evacuation Use Only	●	●	●	●	●	1F

⚠ CAUTION
 The use of evacuation signals on this product, that is not specifically Listed for Fire Alarm Use, is subject to the approval of the Authority Having Jurisdiction.